

2035H

LPG / Gas
Pneumatic Tire Forklifts



Model	Capacity @ 500 mm LC	Fuel Type	Engine
2035H (LPG)	3,500 kg	Dual: Gas/LPG	Nissan K25 / 2.488 L
2035H (LPG)	3,500 kg	LPG	GM3.0 Ncert / 3.0 L
2035H (LPG)	3,500 kg	LPG	GM3.0 Certified / 3.0 L



2035H

Diesel & LPG / Gas • Pneumatic Tire



General	1	Model			2035H(LPG)	2035H(LPG)	2035H(LPG)
	2	Power Type			Dual: Gas/LPG	LPG	LPG
General	3	Base Capacity	@ rated load center	kg	3,500	3,500	3,500
	4	Load Center		mm	500	500	500
	5	Service Weight	unloaded	kg	4,750	4,750	4,750
	6	Axle Load	loaded / unloaded, front	kg	7,275 / 1,700	7,275 / 1,700	7,275 / 1,700
Weights	7		loaded / unloaded, rear	kg	975 / 3,050	975 / 3,050	975 / 3,050
	8	Tire Type			Pneumatic	Pneumatic	Pneumatic
Tires	9	Wheels	front / rear		2 / 2	2 / 2	2 / 2
	10	Wheelbase		mm	1,700	1,700	1,700
	11	Tire Size	front		28x9-15-12PR	28x9-15-12PR	28x9-15-12PR
	12		rear		6.50-10-10PR	6.50-10-10PR	6.50-10-10PR
	13	Tread Width	front / rear		1,000 / 980	1,000 / 980	1,000 / 980
Mast	14	Max. Fork Height	with std 2 - stage mast	mm	3,000	3,000	3,000
	15	Freelift	with std 2 - stage mast	mm	130	130	130
	16	Height, Upright Lowered	with std 2 - stage mast	mm	2,120	2,120	2,120
	17	Height, Upright Extended	with std 2 - stage mast	mm	4,278	4,278	4,278
	18	Mast Tilt, Fwd / Back	with std 2 - stage mast	deg	6° / 10°	6° / 10°	6° / 10°
	19	Carriage	width	mm	1,100	1,100	1,100
	20	Fork Spread	minimum / maximum	mm	272 / 1,072	272 / 1,072	272 / 1,072
	21	Fork Dimensions	T x W x L	mm	50 x 122 x 1,070	50 x 122 x 1,070	50 x 122 x 1,070
	Chassis	22	Length to Fork Face	with std 2 - stage mast	mm	2,730	2,730
23		Overall Width		mm	1,240	1,240	1,240
24		Overhead Guard Height		mm	2,170	2,170	2,170
25		Turning Radius	minimum outside	mm	2,450	2,450	2,450
26		Fork Overhang	with std 2 - stage mast	mm	475	475	475
27		Right Angle Stack	add load length and clearance	mm	4,195	4,195	4,195
28		Ground Clearance	minimum loaded	mm	120	120	120
29			center of wheelbase	mm	135	135	135
Performance	30	Travel Speed	loaded / unloaded	kph	20 / 19	20 / 19	20 / 19
	31	Lift Speed	loaded / unloaded	m/s	0.42 / 0.52	0.42 / 0.52	0.42 / 0.52
	32	Lower Speed	loaded / unloaded	m/s	0.6 / 0.4	0.6 / 0.4	0.6 / 0.4
	33	Max. Drawbar Pull	loaded	kg	2,105	2,105	2,105
	34	Max. Gradeability	loaded / unloaded	%	18 / 20	18/20	18 / 20
Systems	35	Brakes	service		Foot / Hyd	Foot / Hyd	Foot / Hyd
	36		parking		Hand / Mech	Hand / Mech	Hand / Mech
	37	Engine	manufacturer		Nissan	IMPCO	IMPCO
	38		model		K25	GM3.0 Ncert	GM3.0 Certified
	39		emission compliance		N/A	N/A	EPA Tier IV
	40		cylinders		4	4	4
	41		displacement	L	2.488	3.0	3.0
	42		rated power	kW/rpm	37.4 / 2,300	40 / 2,300	60 / 2,800
	43		max. torque	Nm/rpm	176.5 / 1,600	200 / 1,600	220 / 2,100

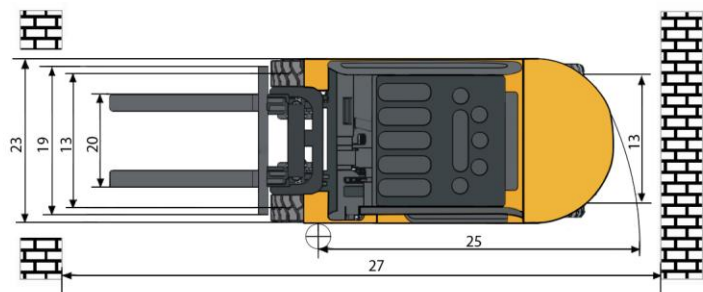
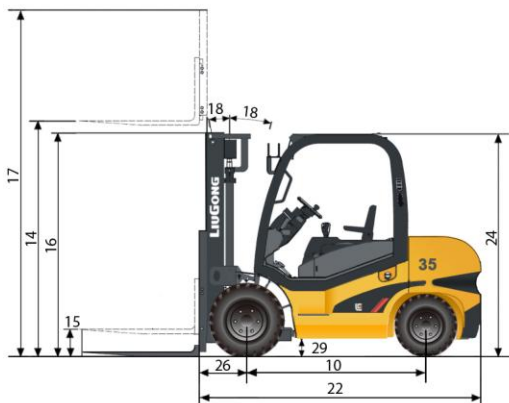

Specifications and designs are subject to change without notice. Machines shown may include optional equipment.